

# Design of intelligent wallpaper installation robot

Cheow Wen Bin

School of Engineering

Asia Pacific University of Technology and  
Innovation (APU)

Kuala Lumpur, Malaysia

tp038709@mail.apu.edu.my

Chandrasekharan Nataraj

School of Engineering

Asia Pacific University of Technology and  
Innovation (APU)

Kuala Lumpur, Malaysia

Chandrasekharan@staffemail.apu.edu.my

Shamini Patpanavan

School of Engineering

Asia Pacific University of Technology and  
Innovation (APU)

Kuala Lumpur, Malaysia

shamini@staffemail.apu.edu.my

**Abstract**—This research focuses on designing and fabricating a solution to the people to assist them in wallpaper installation process. In the project, various methodology will be integrated as a whole system. This includes image processing and stepper motor controlling. The performance of the prototype was evaluated in four tests and its observation. It was found that the accuracy of wall paper pasting ability of the robot was more than 90% accuracy in the four different trails. It also observed effect range of the mobile hotspot is at about 450cm, which is acceptable for controlling the robot over a distance. However, at 900cm away from the robot, the response time becomes even much longer, which may lead to certain issues or even accidents. The confidence score remained high throughout the test, with the minimum score being 85.81%. The statistics shows the wall paper installation robot performs well and supports significantly to reduce the human intervention.

**Keywords**— Wall paper installation, smart robot, image processing, GUI.

## I. INTRODUCTION

Wallpaper is a material for interior decoration which allows people to bring stylish textures and designs on their wall without the need to paint. There are professionals who provide wallpaper installation service to residential and commercial buildings. However, even the fastest possible service still requires certain amount of time as well as high energy consumption. Other than that, the installation process has a risk to cause muscle injury to the installer from incorrect posture when trying to reach a certain height. The wallpaper installation may also suffer from known difficulties such as misalignment, bubbles and creases. As such, a solution or tool that can replace human installer is needed to reduce safety risk and to provide consistent quality in installation of residential wallpaper. The tool should possess certain intelligence to evaluate the outcome as well as time efficient. It should also be able to detect the problems in wallpaper installation, namely the alignment and the wrinkles, to make sure that the process outcome is ideal [1].

Moreover, the presence of autonomous machines or robots can be seen in almost every industry in the modern days. Thanks to the massive development of robots due to high demands, the robots nowadays are manufactured to handle almost all kinds of complex industrial tasks in order to replace human workers. With the current development stage of the robots, one would expect a robot to be already designed for the repetitive and exhausting activities such as wallpaper installation. However, the installation process of wallpaper is still yet to be automated due to the complexity of wallpaper installation in certain cases. The complex problems are such

as difficulties to install wallpaper on edges and to adjust so that the wallpapers are installed on perfect place without overlapping with another wallpaper. To solve the technical difficulties which have some engineers scratching their heads, cutting-edge technology will be required to design a robot which can actually install wallpaper close to a human's performance.

In the modern days, there are various kinds of machines or robots which provides assistance on activities like installing wallpaper. However, they require physical operation by the operator which is inconvenient. For example, the operator of a wallpaper installation machine is required to hold the machine with great accuracy during the installation process. Otherwise, the accuracy would get affected negatively where the wallpaper will be pasted falsely from the desired location. Losing accuracy is one of the worst cases that can be seen in the wallpaper installation field. This is because when a single wallpaper is misaligned, the alignments of the rest of wallpaper pending installation are likely to be dislocated as well. In addition to that, the wallpapers might even overlap with one another, causing the visual quality to drop severely. One can explain this situation as a butterfly effect.

Other than that, the current machines are also "immobile". This term does not imply that they can't be moved around, but rather because they simply can't move to desired location on their own. As a result, the operators are forced to carry the machine around regardless of their heaviness. This could flood the human operators with overwhelming fatigue or even lead to serious health problems such as muscle injury.

Additionally, it is also visually difficult to place the machine accurately without visual guidance. This means that the operator must adjust the positioning with their estimation. Thus, the proposed system will be equipped with laser sight to assist the human operator in aligning the machine before installing wallpaper. Sensing and communication are the two major functions of the WSN [2-5] while IoT is the most innovative resource in manufacturing, commercial, and residential structures every day, playing a critical role [6].

In summary, an actual wallpaper installation machine is in fact yet to be designed. There are similar robots which could assist in other tasks such as wall painting. The ideas proposed in this project will be able to benefit the wallpaper installation industry in many ways. Time and energy as well as labour cost could be saved if the project is successfully implemented. The machine vision and image processing will provide consistent quality in wallpapers installation as it helps the machine to ensure the perfection of wallpaper alignments. This could greatly encourage the people to look for wallpaper installation

service since the process will be much easier and faster. Additionally, the project would also inspire other similar products such as wall cleaning robot or wall painter robot.

## II. LITERATURE REVIEW

It gives an overview about related studies and analyses that were conducted by various researchers prior to the current “intelligent wallpaper installing robot” project. The theories, techniques and methodologies contributed by the researchers that are usable will be referenced to identify the limitations and difficulties faced in the previous studies to bring out the improved work.

Object detection will be implemented on the wallpaper installation robot to align the wallpapers so that they are installed in correct positions. [7] proposed an implementation of real-time object detection algorithm using Haar-like feature selection with OpenCV in an embedded platform. The main purpose of the system is to detect specific location and size of multiple target objects in an image or video. According to the researchers, many publications of object detection were already available. However, the accuracy of the proposed works varies and lacks to meet the optimum level. Other than accuracy, response time is also a key that determines the overall performance of the detection system.

A mobile app will be designed to allow the device to be controlled wirelessly. Researchers in [8] proposed a home automation system which features wireless and voice command remote control from any android device. The system is designed with the aim to provide support to the needs of people while also providing safety control for the switches and electrical appliances using user-friendly interface. This research will be used as a reference for the wallpaper installer robot for wireless connection using noded from an Android mobile. The installation process of the whole system is also designed with simplicity in mind to keep it easy to even amateurs. For network management and remote access feature, a raspberry pi is chosen as the computer unit since it has Bluetooth and Wi-Fi modules.

[9] proposed a deep learning method which parses large-scale 3-dimensional point clouds automatically using Convolutional Neural Network (CNN). The algorithm in this deep reinforcement learning method can detect a target object from a certain class in a big picture which contains other objects. It is done by estimating the target’s approximate location and identifying its special feature in the image. This is because the CNN can learn shape features and encode them into 3D CNN feature in training. After that, background subtraction is performed on the target object for further processing. This method was inspired by the behaviour of human vision where human decide where to look during a search by using rough estimation.

[10] proposed a single-shot refinement neural network used for object detection which has greater accuracy compared to common neural networks. The main purpose of using the single-stage approach for object detection is because of its high efficiency in computation. However, it has lower detection accuracy compared to that of two-stage approach like Region-based Convolutional Neural Network (R-CNN) due to imbalance of class. To solve this problem, the researchers proposed an approach which uses a single-stage framework that is composed of inter-connected modules, ARM and ODM. This approach is expected to increase the

accuracy of single-stage framework to match that of the two-stage framework while maintaining the computational efficiency of single-stage approach. The single-stage neural network is called the RefineDet, which has two inter-connected modules namely ARM and ODM. The module ARM improves efficiency of detection by removing unwanted areas of image, while the ODM reverts object locations to perform a prediction of multiple class labels.

[11] proposed an object detection system using faster R-CNN. R-CNN is said to have comparatively low detection times and has a fairly high classification accuracy. Regional proposal networks (RPN) is used in object detection to detect object while the regional convolutional neural network (R-CNN) is used to classify the detected object. In the proposed system, the two algorithms are unified into one process for higher efficiency. Fast R-CNN is an algorithm made to reduce the repetitive computation of convolution features to just once which could save a lot of time in the process. Unlike the common R-CNN where the region proposals are fed directly to CNN, the CNN is fed with the input image in Fast R-CNN. Thus, the overlapped parts of the image will not be sent repetitively by using Fast R-CNN.

[12] proposed an automatic guided wall painting robot using a Raspberry Pi 3 module and its embedded camera module. The robot is guided by wall dimensions using image processing and paint colour input from user. A 2-D plotter which is controlled by two stepper motors is used as the end-effector that receives command from Raspberry Pi via its Bluetooth module.

In a research work, [13] stated that wall plastering is a difficult main procedure on a construction site to get smooth and finished wall surfaces. To carry out this procedure, skilled labours must work repeatedly using hand instruments. Time consumption and lack of human power reduce the working efficiency on this procedure. Therefore, wall plastering machine is designed to reduce human work and save time. A RISC CPU with single cycle instruction is used as the microcontroller for the machine to ensure high-speed execution of code and low power consumption.

Researchers in [14] studies on the real-time object detection using OpenCV and deep learning with various algorithms. In the research, two of the most popular algorithms, namely the Single Shot Detector (SSD) and MobileNets are implemented for object detection due to their simplicity. The SSD algorithm uses the VGG-16 architecture which makes the implementation fairly easy for SSD. In SSD, the image scanned will be filtered with a number of feature maps. A prediction or confidence score will be evaluated once an object is detected based on the classifier. MobileNets on the other hand is more suited for embedded applications without process control. A less complex neural network is formed during the training using MobileNets algorithm due to its method of convolution which is called the depth-wise separable convolution.

[15] have proposed a method to detect contour, shape and colour using OpenCV in Python. The method can be followed with the requirement of Python OpenCV installation on either Linux or Windows machine. This method will be referenced for the wallpaper installer project for the prototype system to be able to detect the installed wallpaper correctly for position referencing. The installation of Python 2.7, NumPy and

Matplotlib packages must be done before starting the implementation.

In this work, the mechanisms used for the wall plastering machine like vertical rail guides and DC motors with encoder are realistic and practical, in terms of availability and price in Malaysia. On the computer vision side, the most relevant neural network algorithm is selected for the wallpaper installation device to identify the location of wallpaper in the image taken by camera module is selected. The YOLOv2 is rejected despite its higher speed and accuracy. This is due to its absurd specification requirement of microprocessor which the Raspberry Pi lacks.

The CNN-type and SSD algorithms are preferred over Haar-like feature which requires to be hand-engineered whereas the CNNs can be trained to identify wallpapers of different colours and patterns. Among the remaining algorithms, although the CNNs are faster and more accurate, they take a toll on the Raspberry Pi which is the selected microprocessor for the project. Therefore, the SSD is a better option for Raspberry Pi and thus selected.

### III. PROPOSED SYSTEM AND ITS OPERATIONS

Fig.1 shows the block diagram of the overall irrigation system. The block diagram is consisted of a Linux-based microprocessor (Raspberry Pi 3 Model B+) and a microcontroller (Arduino Mega), which are the major parts of this project. The graphical user interface (GUI) will be made on MQTT dashboard based on the Node-red service on Raspberry Pi. The data will be sent and received from the android device via the GUI application. This means that the android user can easily monitor and control the robot at the same time with a single application. The camera will be placed at a position on the robot such that it can capture the wall in front of the robot in the form of image or video.

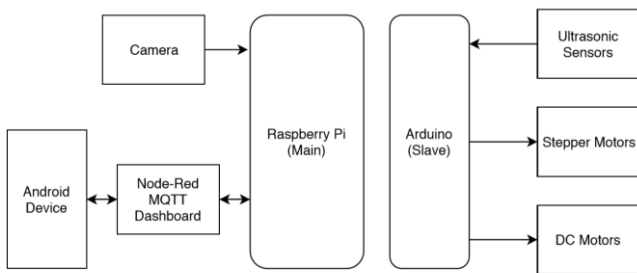

Fig. 1. General Block diagram

The captured image or video stream is then sent to the Raspberry Pi for image processing to determine where should the next wallpaper be installed. The Raspberry Pi receives and gives instruction to the slave Arduino via USB or I2C serial bus connection. The ultrasonic sensors are placed in front of the robot as well as the sides to ensure the robot doesn't crash into a wall or any obstacle.

In fact, the other main purpose of the ultrasonic sensors is to detect if the robot is touching the front wall before installing wallpaper. The Arduino will send the correct number of steps to the stepper motors so that the stepper motors move at appropriate speed and direction to move the main frame which carries the tools and equipment to install wallpaper, based on the input from Raspberry Pi. The

Arduino also controls the DC motors for wheel movement by receiving instruction from Raspberry Pi.

#### A) Work flow Chart

Fig. 2 displays the main flowchart of the system based on proposed methodology. The Pi camera module is initiated by the Raspberry Pi upon starting the robot. The system then uses the ultrasonic sensors to detect if the robot is facing a wall. If the robot is not against a wall, it will read the distance repeatedly until the robot is manually brought to face the wall. The status of the robot such as its distance to wall and whether or not it is ready to use are updated to the GUI via MQTT dashboard. Once confirmed that the robot is against a wall, the system will start receiving captures from the camera. At the same time, a bounding box will be drawn and shown on the video stream on GUI to let the user know where the robot is currently aiming at. Firstly, the system will check for wallpaper on the wall for position referencing. If there is no wallpaper for reference, it will prompt user for manual position input and wallpaper will be installed to that exact position. Otherwise, the system will detect the previous wallpaper by using object detection. Then, the system will prompt user to input the position with only two choices – left or right. The algorithm will align the current wallpaper to the direction which the user has instructed beside the referred wallpaper. A visual indication of the to-be-installed wallpaper is shown to the user on GUI to ensure that the wallpaper will be installed in the right place. After that, the robot will move to the direction towards where the visual indication drawn on GUI is located until the visual indication is at the center of the GUI screen. This means that the robot has arrived at the destination to install the wallpaper. It is then clear to proceed to install the wallpaper on the desired location.

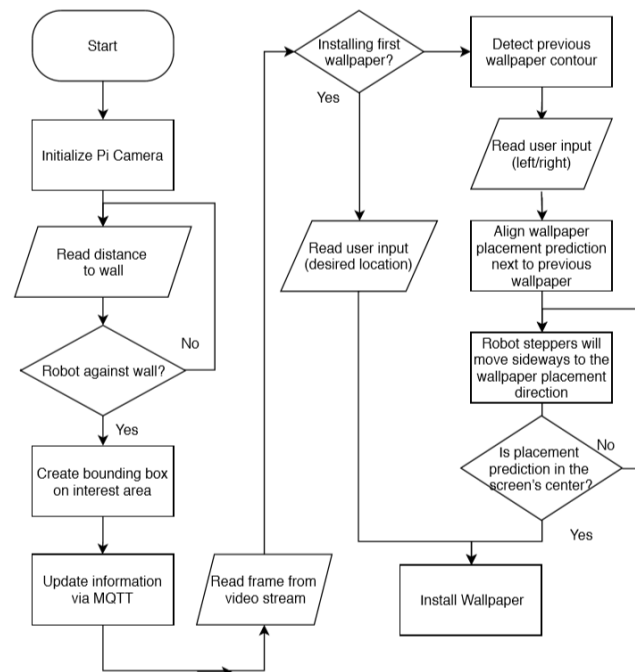

Fig. 2. Data acquisition diagram

**B) Model Design:**

The concept design was first done by using hand-sketch on several A4 papers. Once the final design has been completed, the prototype was then re-designed using a computer-aided design (CAD) that the students have used throughout the university projects which is SolidWorks. SolidWorks is chosen as the CAD software due to the familiarity and experiences with it. The CAD is able to give visual representation of how the prototype will function. For example, the complex moving parts of the prototype can be shown and explained by using the assembled parts which are difficult to be described using words otherwise.

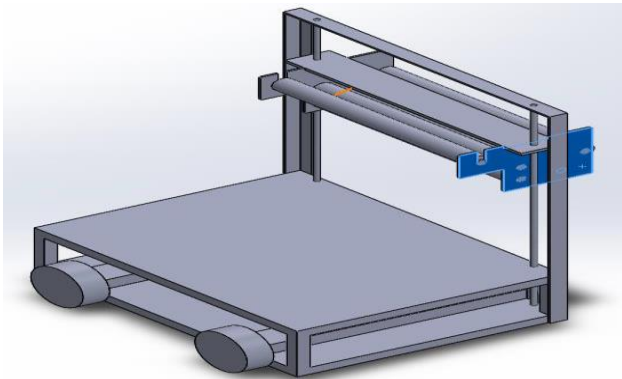

Fig. 3. 3D model of prototype

**C) System Implementation**

Fig. 4 shows the prototype of the Wallpaper Installation Robot including the integrated connection and components. The main frame is where the installation of wallpaper operates. It utilises two leadscrews where each of them is powered by a stepper motor positioned below the platform. When both the leadscrews rotate clockwise, the main frame is pushed upward and vice versa for counter clockwise. An aluminium platform is built next to the main frame to mount the Pi camera module for capturing image of wallpaper at suitable distance. The camera is connected to Arduino board located at the lower frame by a 5-metre FFC cable. Two bearings held by L-shaped aluminium supports serve as “propellers” to keep the robot parallel to the wall and at the same time allows the robot to be located at exact distance from the wall.

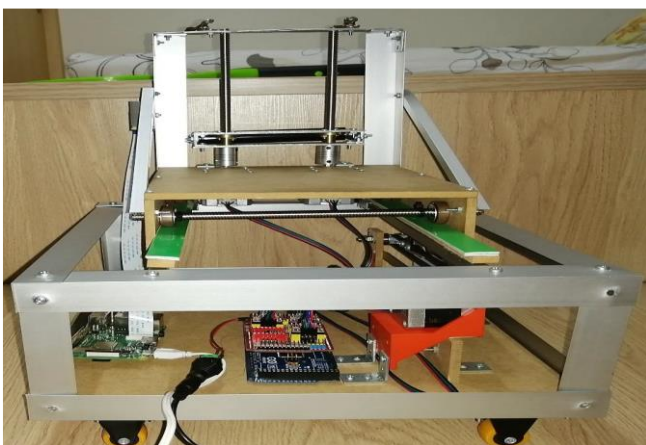

Fig. 4. Prototype model

At the middle of the robot, the platform used to hold the main frame can be moved forward and backward by utilising a belt drive system. It is constructed with two leadscrews to hold six bearings and washers to reduce friction when moving. The belt drive system is consisted of a stepper motor which pulls a timing belt attached to the platform for Y-axis movements. At the bottom, two computers can be seen where one of them is the Raspberry Pi board, and the other being the Arduino board. The Pi board is powered by its own power plug and it also powers the Arduino via an USB cable. The USB cable was not captured as there was a difficulty in trying to include it in the picture for overall prototype. The CNC shield used to drive the steppers is mounted on top of the Arduino board. It is connected to three A4988 drivers which have their potentiometer correctly configured.

**IV. PERFORMANCE TESTING AND SIMULATION RESULTS**

The overall performance of the developed system has been evaluated by conducting various simulations and relevant tests.

**A) Bubble detection accuracy**

This testing was conducted to compare the number of detected bubbles against actual number of bubbles spotted by human eye on the pasted wallpaper. Even for machine, there will be mistakes during image processing where the target of detection is irregular. The bubbles and creases come in different irregularities, including size and shape, which results in their visibility. The number of bubbles detected from the same wallpaper will always be similar or even constant due to the algorithm. To test the difference in bubble detected and spotted by human eyes, the wallpaper should be re-pasted to the wall to change the control variable.

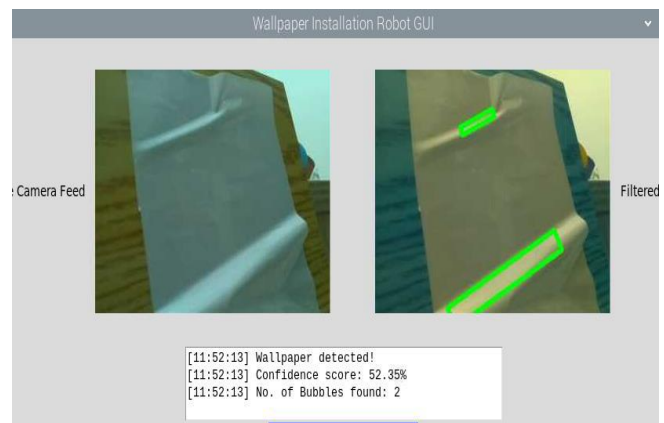

Fig. 5. Bubble detection accuracy

Furthermore, a number of bubbles increases on wallpaper should be intentionally made without making too much damage to the wallpaper. The location of the installation activity should remain the same throughout the test. The total number of detected bubbles on the wallpaper is retrieved from the GUI. The actual number of spotted bubbles is collected by counting the bubbles with two persons to ensure high accuracy. The different trials indicate data being collected every time the wallpaper is re-pasted. Fig. 5 shows an example of a test to compare the actual number of bubbles. The number

of detected bubbles is two, as shown in the text box. Further tests will have more bubbles created on the wallpaper then counted by both human and machine vision.

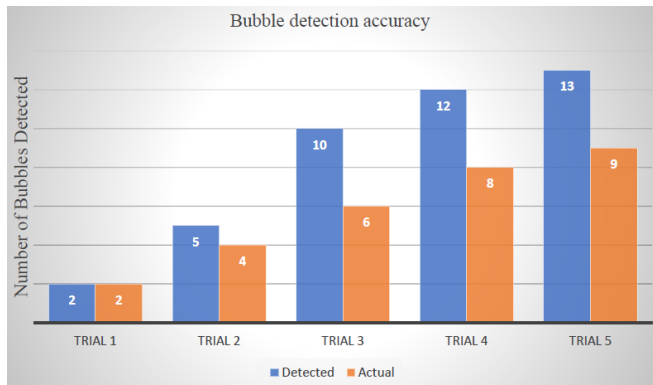

Fig. 6. Bubble detected in five trials

Fig. 6 shows the number of bubbles spotted of machine vision and human eyes side by side. More bubbles were created after each test to create a larger field of comparison. While in the first trial, both the machine and human have spotted two bubbles, which means that the computer vision has correctly identified the bubbles on the wallpaper. However, the difference in number is shown in other trials where the computer has mistaken some bubbles to be less or more than their exact number. At trial 3, the difference becomes very obvious as shown where the actual number of bubbles is much less than that of the computer vision. This happened due to some bubbles being difficult to distinguish against the surrounding pixels. The factors can be blurry image, different lighting on an area of detection, intersection of bubbles or creases and so on.

**B) Installation time against power supplied to prototype**

This testing was conducted to compare the different voltage level supplied to the prototype’s stepper motors to the time required for the Wallpaper Installation Robot to complete installation of a wallpaper. It is known that if a stepper motor is not supplied with sufficient power, it becomes slower, outputs less torque and might even skip a few steps. This may happen during the robot’s operation as it is powered by a 12V lithium-ion battery which can drop after an amount of time. The decrease in the voltage level may affect the installation performance in a negative way.

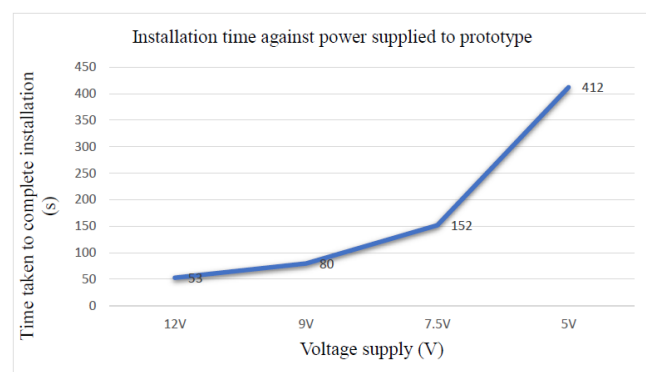

Fig. 7. Installation time taken against power supplied

To imitate the phenomenon of voltage drainage, the main 12V Li-Po battery plus three batteries with 9V, 7.5V and 5V were used as the power supply one at a time. All the batteries were fully charged and have a total of 1A current output. Then, the automated installation is initiated from the GUI and a stopwatch to record the time taken is initiated.

Fig. 7 shows the line plot of time taken for installation in second against the voltage supplied used to power the stepper motors. The relationship of the two variables can be seen as indirectly proportional as less voltage level results in longer time taken for the whole process to finish. The reason behind this phenomenon is logical as power output is directly proportional to the torque and speed of stepper motor. From the figure, it is observed that the difference in time taken of the weaker batteries are exponentially larger. The reason behind the huge difference between 5V and 7.5V batteries is due to the 5V battery being insufficient to power the stepper motor which requires 12V. On the other hand, the 9V and 7.5V batteries are still in acceptable voltage output range for the stepper motor.

**C) Accuracy of wallpaper pasting**

This testing was carried out to determine the accuracy of wallpaper installation to evaluate the performance of the prototype. The pasted wallpaper can result in the appearance of bubbles, slight deviation from intended location as well as the alignment. At a fixed place, different wallpapers will be used one by one in the test to ensure the peak quality of wallpaper being pasted. Reused wallpapers might have weak adhesive which may lead to unwanted imperfections when pasted again. After installation, the left side of an ideal pasted wallpaper should match two points on the wall. The mentioned two points is drawn on the D.I.Y wall at the head and tail of the line in GUI which indicates the designated alignment to install wallpaper. If the wallpaper is not aligned to the drawn line, the distance of line from point A and from point B in X-axis is calculated.

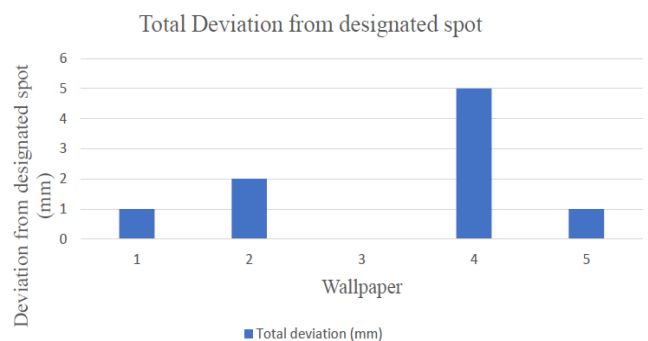

Fig. 8. Test result of wallpaper deviation

Fig. 8 shows the calculated total deviation or error from the designated points A and B in five different wallpaper installation tests. These test results indicate that the accuracy of the wallpaper installation robot is not 100% as there are various factors affecting it. The most significant factor is when the wallpaper is being clipped onto the clippers before being pasted. At the third test, there was not a single bubble or deviation detected. This has resulted in a fairly high confidence score, as the score is an overall evaluation which includes the number of bubbles and alignment of wallpaper.

This can also be proven by the fourth test where the confidence score is very low even though there was only one bubble. The reason behind such a low confidence score is its deviation from the target points, indicating that the wallpaper has misalignment. From the deviations and number of bubbles detected, the confidence score from pattern matching is also proven to be functional as it is heavily affected by these imperfections.

#### D) Latency of GUI over distance

This test was conducted with the purpose of measuring the delay time of GUI input to the computers over different distances. Since a mobile hotspot will be used to create a server for remote connection from an Android device to the robot, the range of connectivity is heavily limited unlike the Wi-Fi connection from routers. The setup of this test involves using an external application which is called Fing. Before beginning the test, both the Android device and the Raspberry Pi should connect to the hotspot. Then by using the Fing app, the time taken for packets to be sent from the Android device to the Pi is observed and recorded. The test will be repeated seven times at fixed distance interval between the Pi and the Android device.

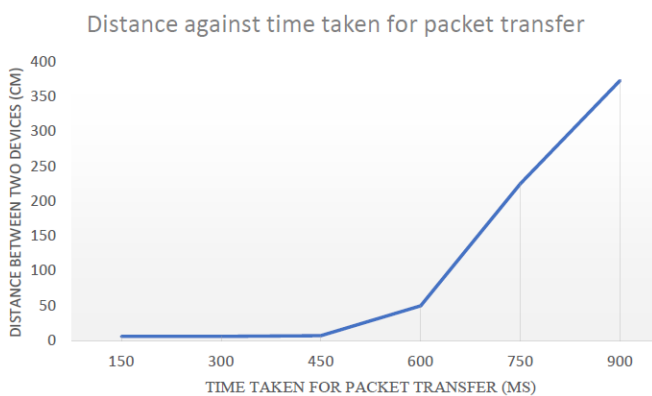

Fig. 9. Time taken for packet transfer over distance

Fig. 9 shows how the connectivity between the Pi and the Android device deteriorates over time. While the connectivity range varies with the model of Android device, the relationship between the distance and time taken for the GUI input to reach will be the same. Moreover, the connectivity range of modern mobile devices are similar to this since similar components are used for modern Android devices. From the figure, it is seen that the response time deteriorates significantly after 450cm. This means that the effect range of the mobile hotspot is at about 450cm, which is acceptable for controlling the robot over a distance. However, at 900cm away from the robot, the response time becomes even much longer, which may lead to certain issues or even accidents. Therefore, when remote controlling the robot via GUI on VNC connection, it should be noted that the user should stay within a meter for maximum response time.

#### V. CONCLUSION

An intelligent robot to reduce the human intervention in the wall paper installation process is presented. It is developed

the GUI over the Blynk cloud server for controlling and monitoring the system. The system has implemented by integrating the microcontroller, and stepper motor with IOT platform. The performance of the prototype has been evaluated and found 90% accuracy of wall paper pasting ability of the robot, and operated range of mobile hotspot is at about 450cm, which is acceptable for controlling the robot over a distance. The confidence score remained high throughout the test, with the minimum score being 85.81%. Despite having slight imperfections, the wallpapers are properly pasted onto the wall without having noticeable bubbles or wrinkles.

#### REFERENCES

- [1] Particke, R. Kolbensschlag, M. Hiller, L. PatiñoStudencki and J. Thielecke, "Deep learning for real-time capable object detection and localization on mobile platforms" in , IOP Publishing Ltd., no. 261, pp. 1756-1763, 2017.
- [2] T. Eldemerdash, et al., "IoT Based Smart Helmet for Mining Industry Application," *International Journal of Advanced Science and Technology*, vol. 29, no. 1, pp. 373-387, 2020.
- [3] Al-Gumaei, W., Selvaperumal, S.K., Abdulla, R. and Nataraj, C. , "Research Article Smart Tree Care System with Internet of Things," *Research Journal of Applied Sciences, Engineering and Technology*, 15(9), pp.328-336, 2018.
- [4] F. S. Hon, R. Abdulla, S. K. Selvaperumal, Nataraj, C., Ratnadurai, D., 2020., "Wheel Chair-Person Fall Detection with Internet of Things" *Solid State Technology*, 63(1s), pp.911-922, 2020..
- [5] W. M. Rasheed, R. Abdulla, L. Y. San., "Manhole cover monitoring system over IOT," *Journal of Applied Technology and Innovation*, vol. 5, no. 3, 2021.
- [6] R. Abdulla, S. K. Selvaperumal., "Active RFID System with Wireless Sensor Network for Power Efficiency. *Journal of Applied Technology and Innovation*, vol. 2, no. 1, 2018.
- [7] S. Guennoui, A. Ahaitouf, A. Mansouri, "A Comparative Study of Multiple Object Detection Using Haar-Like Feature Selection and Local Binary Patterns in Several Platforms", *Modelling and Simulation in Engineering*, vol. 1(8), 2015.
- [8] J. T. Hodges, and R. Ciurylo, "Automated high-resolution frequency-stabilized cavity ring-down absorption spectrometer," *Rev. Sci. Instrum.* 76, 023112 (2005).
- [9] F. Liu, S. Li, L. Zhang, C. Zhou, R. Ye and J. Lu, "3DCNN-DQN-RNN: A deep reinforcement learning framework for semantic parsing of large-scale 3D point clouds", *Proc. IEEE Int. Conf. Comput. Vis.*, pp. 5678-5687, Oct. 2017.
- [10] S. Zhang, L. Wen, X. Bian, Z. Lei and S. Z. Li, "Single-shot refinement neural network for object detection", *Proc. IEEE Conf. Comput. Vis. Pattern Recognit.*, pp. 4203-4212, Jun. 2018.
- [11] M. Lokanath, K. Sai Kumar and E. Sanath Keerthi, "Accurate object classification and detection by faster-RCNN", *14th ICSET-2017 IOP Conf. Series: Materials Science and Engineering*, vol. 263, pp. 052028, 2017.
- [12] Madhira, K., Mehta, S., Bollineni, R. And Kavathia, D., "Automatic Guided Wall Paiting System in Nirma University", International Conference on Engineering, New Jersey, 23rd-25th November 2017. pp.1-5.
- [13] A. N. Askar, L. P. Raut, "Design of Automatic Wall Plastering Machine", *International Journal of Engineering Sciences & Research Technology*, 6(3), 2017.
- [14] G Chandan, Ayush Jain, Harsh Jain and Mohana, "Real time object detection and tracking using Deep Learning and OpenCV", *International Conference On Inventive research in computing Applications (ICIRCA-*, pp. 1327-1330, 2018.
- [15] R. Puri, A. Gupta, M. Sikri, "Contour Shape And Color Detection using OpenCV – Python", *International Journal of Advances in Electronics and Computer Science(2393-2835)*, vol. 5, no. 3, Mar. 2018.