

Development of Smart IOT Based Power Adapter

Arun A/L Attappan
 School of Engineering
 Asia Pacific University of Technology
 and Innovation (APU)
 Kuala Lumpur, Malaysia
 tp038891@mail.apu.edu.my

Jacqueline Lukose
 School of Engineering
 Asia Pacific University of Technology
 and Innovation (APU)
 Kuala Lumpur, Malaysia
 jacqueline.lukose@staffemail.apu.edu.my

Kumaresan A/L Magaswaran
 School of Engineering
 Asia Pacific University of Technology
 and Innovation (APU)
 Kuala Lumpur, Malaysia
 kumaresan.m@staffemail.apu.edu.my

Abstract—The main aim of this research is to develop Smart IOT based Power Adapter. In this proposed method, a Smart Power Adapter was developed along with the BLYNK mobile application to control and monitor the electrical power consumption. The performance of the developed smart power adapter is evaluated by testing the accuracy of power consumption for each home appliances, Battery capacity testing, cost of power consumed data for different home appliances, Cost saving with smart power adapter features and without features. Finally, the testing on changing the voltage sensor value for most prominent value for power consumption. It is observed that the approach for calculating the power consumed by home appliances shows least error of 0.1%. Where else, the battery power back up on the adapter only provide 5 hours of continues power usage. Besides that, the wireless control over the power adapter works flawless along the time scheduling. Finally, the smart power adapter estimates the costing of the power consumption relying on the usage of electrical power with least components.

Keywords—IoT, Power Adapter, NODE MCU, BLYNK application

I. INTRODUCTION

Smart homes provides electrical power to the devices through the power supply socket, which have is the only way to get the power source at home. The power Adapters are not improved as quick as other everyday smart devices even though they can be said as it is the best role to be changed more intelligent as smart homes are rising popularly. Using power supplies unlimitedly without realizing the power consumed and wasting the power unwantedly. The effort from human and the resources from earth's crust to generate electricity are a lot. Wasting electricity will add amount of fossil fuels and other natural resources that are already being depleted at very high rate. As a solution for the humans to have concern about the consumption of power supplies and control the usage, there should be a development on smart power adapters that plays a role to control wirelessly, and consumption monitoring. It should also involve security integration to have authority none other than the user. The cost should kept as low as possible by optimizing the design The backup power when there is no electricity. In the case of emergency, electricity that provides source to charge mobile phone and lights are important. Finding the backup solution for sudden power cut is essential.

In this new era of technology, coming up with electrical and mechanical development makes our lives more convenient. It's all about how to save power and how to provide the flexibility of use to the society [1]. The internet of things (IOT), gives benefits to connect the electronic devices,

sensors, software and other technology component around us. Implementing a smart components to the power adapter will provide the authority to control on and off the current flow via wirelessly. This saves some percentage of energy. Power adapter that are usually used in home and other places are just for different pin compatibles but by providing the intelligence to the power adapter helps to save money on energy use. The cost for simply forgetting to turn of the electrical appliances can increase over time. Besides that, prevention of electrical fires and electrical shocks are also concerned when it comes safety.

[2] introduces the intelligence of electrical outlet for each hardware modules. The adapter feedback mechanism and the electrical power management is received and communicated wirelessly with the help of software interface. A memory Module is used to store the data and other internet parameters. [3] introduces the method for developing awareness on the cost of the energy metering and connected to the IOT for monitoring and commanding the electronics Devices. This journals, uses the principle of hall-effect which the voltage will rise during the placement of current at the magnetic field. [4] proposes the idea of reducing the power consumption in technical universities by the power distribution agencies across the world. They introduced the system that involves thermal sensing and IOT enabled Microcontrollers for the working. [5] introduces the system based on WSNs and IOT technology to manage real-time power at buildings. This proposed systems consists of Pre-build mobile applications, sensing node and base station. [6] proposes the idea of autonomous power control system wirelessly in a user friendly and controlling the power appliances and security of the house. Using the Intel Galileo Gen 2 development board, attached with the temperature, smoke and PIR Motion sensor to form the system. Receive and send over internet and view the status from Android app. This journal have a lot of components and the power monitoring system is bigger. [7] shows the analysis which provides the smart plug that controls the switching power supply according to the environmental changes and attached sensor for different application environment. A deep learning method is used to for the model to learn, update and improved continuously to increase the intelligence of this system. [8] proposed a system then ensures the electrical safety by instant cut connection of the power supply in case of any fault happens. This system also involves notification event through an advanced communication interface and real-time monitoring by using a data concentrator architecture.

IOT Based Power Monitoring System and Control approach has been studied by many researchers [9-12]. [13] designed an efficient and real-time wireless networks to monitor power consumption of electrical appliances. Android studio software is used to develop the android application to show the electrical parameters. The mobile app send information to the cloud and the data will send to the raspberry pi to receive the control statement from the Mobile application. [14] proposed the concept of fundamental understanding of voltage transformer and the construction for the rechargeable charging battery that involves circuit. The construction is mostly made of bread boarding. This system switches to the battery when the power failures. [15] proposed an automatic electrical bill from the meter. The idea is to develop power meter to have inbuilt printer to print bill every end of the month. To reduce the manpower on delivering the bill at each house. Calculating the cost accurately by the usage power is very well explained in the journal.

The things that are missing from most of the previous researches is the idea of implementing, time scheduling for the adapter to turn on and off at certain time based on our preference. Besides that, the power adapter does not have any security that enables the person in authority to change the power adapter's parameters and settings. Having a password security to turn on and off by the person in use will allow some privacy from other users to overlap the usage. Furthermore, from the research, most of the system are not seems to fit in a compact size adapters. The design should be small and compact to fit into the small power adapters. Most of the time, a power adapter will be used to charge mobile devices. The power consumption can be reduced by sending the status of the battery when it is full to turn off the power adapter. This could be helpful to monitor the batter percentage of the mobile phones. Moreover, the gaps that were found on all the journals is, there is no a backup power enabled in any of the power sockets or adapter when there is no electric current supply. This backup idea could save someone from an emergency cases such as charging their mobile phone, supply voltage to power a led lamp in night environment. Involving a battery power backup in smart power adapters will help most people when there is no electricity supplies. This is one of the major improvement that can be implemented in the research.

Therefore, the aim of this research is to develop smart IOT based Power Adapter that monitors the power consume and control wireless. This research is necessary because the IOT based power adapter helps to protect the electrical power supply system against unwanted wastage when it is not in use. The quick improvement of power supply helps our society to live more comfortable. The need for current supply Capacity is increasing day by day in our society. The question what is the possible way to save power and how to address the issue of the general public of power, this region has being the common issues from the entire world, but with the help of internet of things intelligent power adapter will answer the need of power consumption by the consumers of electricity. The system aim to improve the capabilities and add smartness of using power adapter compare to an already existing product by implementing a rechargeable battery power backup if there is no electricity for a moment. This will help the users to receive emergency power source to recharge their mobile phone or can use for powering the light in dark environment. By the help of IOT the project will overcome inefficiency and

ineffectiveness by providing the wireless control on Smart power adapter.

II. System Implementation

Fig 1. shows the entire system using the block diagram. The block diagram start with the 240V AC power supply. The power adapter which has 3 pin plug input will receive the electrical power from the AC current from house power supply. This AC current supply will then need to power the NODE MCU. This NODE MCU is used to program the features connected to this Power Adapter. It also provides Wi-Fi capability to connect devices. Since the AC current is too big to power the NODE MCU a rectifier is used to convert AC to DC power supply of 5V and 3.1A. The rectifier produces two output of 5v with 3.1A and 2.1A. This output power from the rectifier will be connected to the NODEMCU. The NODEMCU then will be the controller for the external features. The 2channel relay will be connected to the NODEMCU. The signal input from the relay to the NODEMCU is connected. The signal in for the relays will then be programmed in the Arduino software. The first channel relay will be connected directly to the AC current supply. Where else, the other channel relay will be connected to the rectifier with an output of 5V and 2.1A. This 5V and 2.1A power is used to charge the rechargeable battery of capacity 5000mAh. The relays will then be programmed by the NODEMCU to control the output. The current sensor will be connected to the NODEMCU as well to read the output signal of current. The live wire from the relay that produces the AC current supply will be connected to the current sensor. Then the current sensor produces the output live wire to the power Adapter. The other channel relay will produce the power to recharge the battery. The battery percentage will be displayed through the LCD display on the adapter itself. Thus there will be 2 output which is the AC and DC power supply. The DC power supply will be used for emergency case as a power bank type.

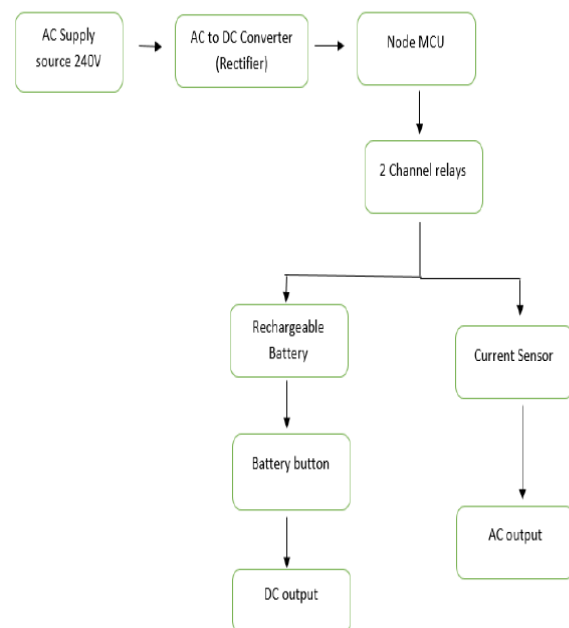

Fig. 1. Overall block diagram

III. Constructional Details

Fig 2. shows wire circuit Diagram which is explained together with the graphical circuit diagram. The wire circuit is displayed to understand the connection of this system more clearly. Besides that, the rectifier is shown clearly with two DC outputs. This system diagram, is improvised from the previous circuit diagram by not including Arduino UNO. The DC output with 12 V and 5v is used to power up the nodeMCU and Battery recharge circuit. The nodeMCU is provided with 12 V so that, the nodeMCU circuit can provide power for the current sensor and relays. Without this power the Relays and the current sensor is not able to power up with requirement voltage. The DC supply of 5V is directly connected to the relay and then connected to the battery circuit.

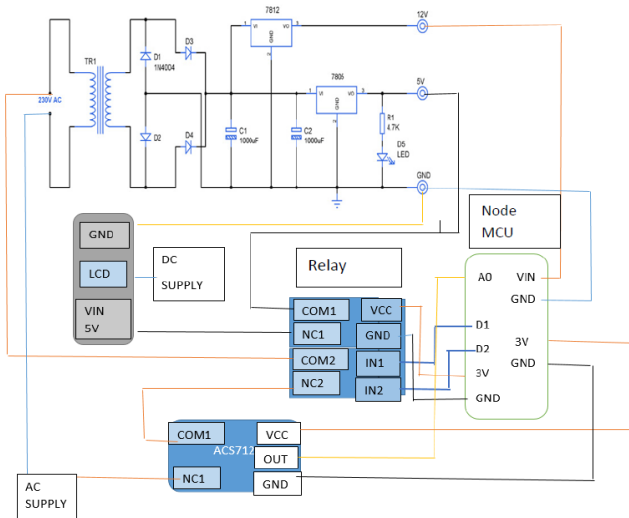

Fig. 2. Wire Circuit Diagram

The AC power supply has single phase plug that contain live, neutral and earth wire. The live wire and neutral wire will be connected directly to the rectifier since the NODEMCU need to be powered by the DC supply as shown in Fig 3. This rectifier will produce DC current with the stepdown voltage of 5V and 2.1A current. The rectifier output that has positive and negative wire will be connected directly on the NODEMCU Vin and ground. NODEMCU has the capacity from 0 to 12V for input power supply, thus the NODEMCU is connected with 5V 3.1A rectifier. Then the signals to control the relays is connected to the Digital pin D1 and D2. This D1 pin is connected directly to the relays signal pin 1 and D2 is connected to the relays signal pin 2. To power the relay, the 3V and ground from NODEMCU is connected. Then the operation is completed by calling the digital pin from the programming code installed in the NODEMCU. The NODEMCU then can operate the relays to turn on and off from the BLYNK Application. The connection between the BLYNK application and the NODEMCU takes place by programming the IP address of the internet connection and password in the Arduino IDE software. The NC1 of the relay one is connected by the AC power supply from the main. The live wire will be connected to the COM1 and as the output the wire will be connected to the COM1. The output of the COM1 then be connected to the current sensor. The current that is being controlled by the relays via BLYNK application need to be monitored the power consumed by the current sensor. This current sensor gets the power supply from the NODEMCU.

The current sensor signal output will be connected to the analog pin of A0. This signal input can be manipulated by the programming code in the Arduino IDE software. Then the current sensor will be giving the output to the main adapter power output socket. Besides that, the second relay is used to charge the rechargeable battery power supply. The power to charge the battery is produced by the rectifier that has another output current of 2.1A and 5v. This power will be supplied to the battery rechargeable circuit when the relay is turned on by the BLYNK application. This two relays will be given with two different button in the BLYNK application. The VIN and ground is connected to the rechargeable battery circuit from the rectifier output power. The battery will charge when the relay is turned on. The remaining battery percentage is then displayed by the LED display on the adapter itself. The LED display is connected to the rechargeable circuit and programmed to show the remaining percentage of power left in the battery. The output of this rechargeable battery is kept separated from the main AC current output for appliances usage. The output of this rechargeable battery power is connected with a USB type B port. This enable easy connection with USB phone charging cables.

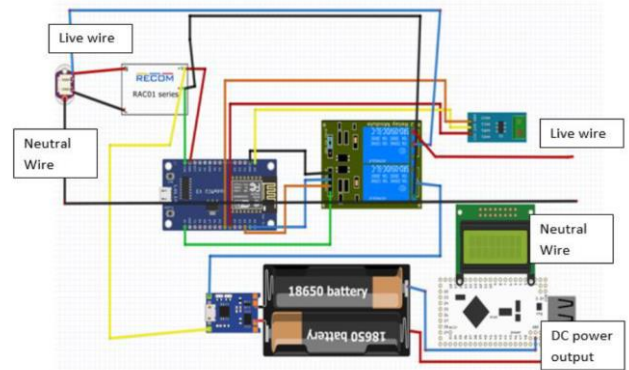

Fig. 3. Graphical circuit diagram

IV. System Overview

A. The smart power adapter

The smart power adapter working principles along the IOT platform is illustrated in Fig 4.

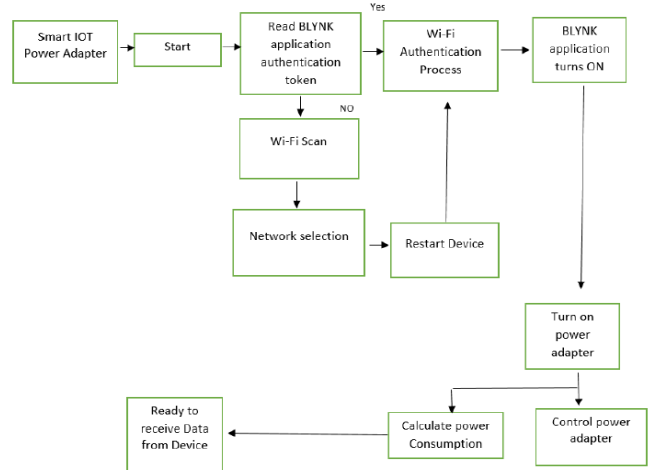

Fig. 4. Power Adapter working principles block diagram

The Wi-Fi connection will be checked along with the BLYNK application authentication token. If the BLYNK application token does not match or takes time to settle, the Wi-Fi will scan for network selection again. The smart power adapter device will restart manually and able to run the Wi-Fi authentication process. Once the authentication runs successful, the Application status will turns ON to proceed. Then the process will able to fully access the mobile application with data and control.

B. Android APP algorithms

The application will display the current value from current sensor ACS712. Based on the Current value more than or less than 0.2 the socket status on the application will indicate whether the adapter is turned on or off. The last cost input data will be in memory until one month and resets the value in the mobile application option button. The last input cost data will carry forward to total up the cost for the current power usage as shown in Fig 5.

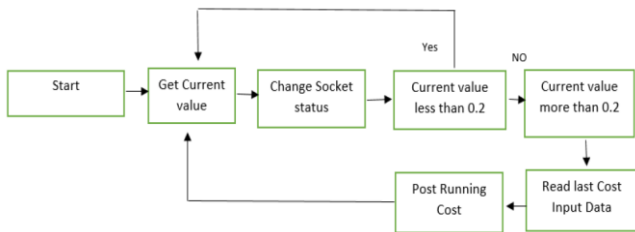

Fig. 5. Application working principle with cost block diagram

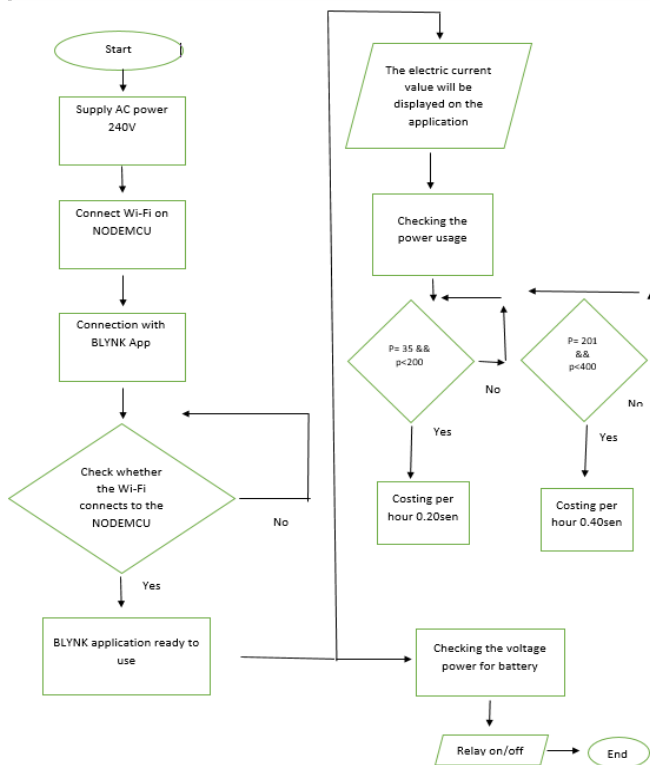

Fig. 6. Complete Application working principle Flow chart

The flowchart in Fig 6. shows the explanation on calculating the Cost for power consumed by the smart power adapter. The beginning stage is based on checking the Wi-Fi connection on the NODEMCU. Then the current and voltage value used to calculate the power Consumed. The calculated power consumed then will be referring to the tariff table to calculate the cost value. Then the cost value will be displayed on the BLYNK applications.

Fig 7. shows the top view of the Smart IOT based Power Adapter. The three pin socket with white frame is attached along the body. The LCD voltage Display will be on the top as shown. The rechargeable batteries are placed beneath the LCD display. The NODEMCU and the relays are also placed beside the batteries. The wire connection is visible on the top view since the other components are placed at the bottom. The size of the adapter is measured and compared with the normal power socket to fit precisely. The power adapter is not very big it can fit to any power source. The rechargeable battery power back up made the power adapter little bigger. The graphical user interface to control and monitor this power adapter is shown in Fig 8.



Fig. 7. Top view without case

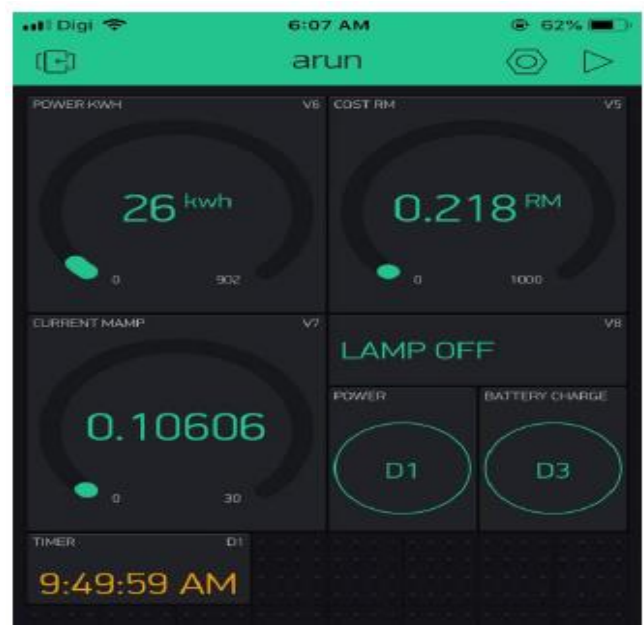

Fig. 8. BLYNK App interface

The smart Power adapter status will be shown on the application by indicating “LAMP OFF” or “LAMP ON”. The power button to turn on the switch is named as “D1”. Furthermore, the backup battery power is connected to the “D3” button besides the main power button. This “D1” and “D2” buttons are assigned on the programming code. Thus this buttons are functional. The Button enables the battery to recharge. The Timer is set up for scheduling the time for the AC Current power to engage any home appliances. The remaining, Current, power and costing will be displayed on the gauge.

V. Testing of the proposed design

A. Efficiency Test 1

The first testing which will be the changes in the voltage number to get the accurate value for the power consumption since the voltage value will be fixed and varied from small amount of range. The range falls from 238V to 245V. The testing values will be obtained with a 3W Light bulb. Finding the error percentage will provide the clear settings to calculate the power consumption cost. The experimental set up is done by manipulating the voltage values in the programming code updated on the Arduino IDE software. In the programming code as shown below, the voltage value is changed and the results of the changes will be shown on the BLYNK application at the power consumed section. Table 1. shows the data collected from the testing. The voltage value is updated from 238V to 245V to find the error percentage from the actual power consumed by a 16W Light bulb.

TABLE I. VOLTAGE VALUE SELECTION TESTING

Vrms(V)	Irms(A)	Power(W)	Actual power (W)	Error (%)
119.2	0.12	14.3	14.5	0.01
130	0.12	15.7	14.5	0.08
150	0.12	18.1	14.5	0.25
170	0.12	20.3	14.5	0.4
190	0.12	22.8	14.5	0.57
210	0.12	25.2	14.5	0.73
230	0.12	27.6	14.5	0.9
245	0.12	29.4	14.5	1.02

The power consumption is being compared with the real voltage and the current consumed by the 16 watt led bulb. This test was first done using the clamp multimeter to find the real value for the power consumed. Obtaining the voltage and current value from the Clamp multimeter, the actual value is obtained. The power consumed by the 16 watt led bulb is 14.5 watts. Thus, this results is used as reference to calibrate the voltage value to find the exact power consumed using this smart power adapter. Besides that, to find the optimum value the error percentage is calculated. The error is not significantly large from the voltage value from 119.2V until 130V. Then the difference shows up when the voltage value increases from 150 V to 245V. This test was conducted since the voltage sensor is not used and to make this device more reliable to calculate power consumption. The obtained voltage value is also tested with other testing results to find any error. But the values are getting related results without noticeable error. Thus, from the results, the voltage value is then selected to be

119.2V for calculating the power consumption for all the appliances. The data analysis is shown in Fig 9.

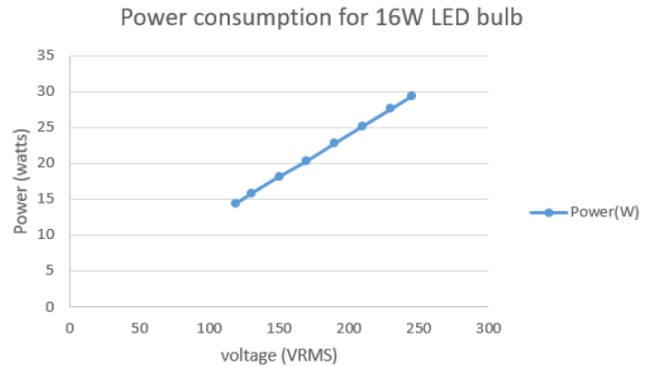

Fig. 9. Power consumption for different voltage value Graph

B. Efficiency Test 2

In this test, the power consumption reading will be recorded with different power appliances at home. This is to check the ability of this smart power adapter to record the power consumed more accurately. The experimental set up is done by connecting the different appliances with the smart power adapter for multiple times to record the power consumed. The table below shows the data of the power consumed in watts.

TABLE II. POWER CONSUMED IN WATTS

Appliances	Test 1 Power(W)	Test 2 Power(W)	Error
16 Watt LED light	14	14	0
Stand Fan 60 Watt	54	54	0
Hairdryer 1200Watt	865	869	0.04
Iron Box 1800 watt	1001	1010	0.09

This test is completed by different home appliances to calculate the power consumed. This test is taken two times by the same appliances to find any changes. The error is also calculated from the testing from the tes1 and test 2 results. From the data above, the results is clearly proven than there is no changes on the testing. The Power consumption is also rechecked using the clamp multimeter for the home electrical appliances. The graph data is shown in Fig 10.

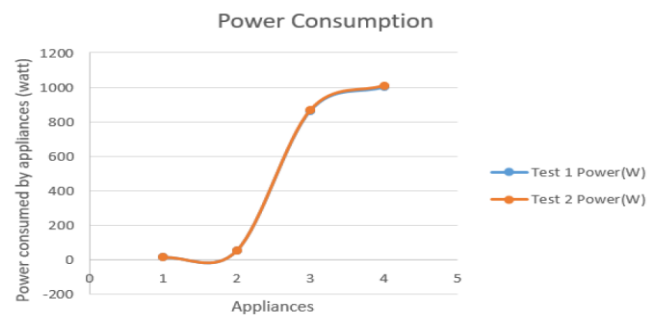

Fig. 10. Power consumption test for different home Appliances Graph

C. Efficiency Test 3

The third testing is based on the Costing amount that is directly reflected from the power consumed per hour. Different appliances with different power consumption is used to calculate the cost consumed by the appliances. The costing is recorded every one hour.

Total of three hours is monitored to check the accuracy of the costing. The different power consumption home appliances are used on the smart power adapter. The power consumed data that shows together with the costing in the blynk application is recorded. This recorded costing data is then checked along with the Malaysian power consumption Tariff table. The table below shows the costing according to the usage of power.

TABLE III. COSTING ACCORDING TO THE USAGE OF POWER

Appliances	16 watt Led light	Stand fan 60 watt	Hairdryer 1200 watt	Iron box 1800 watt
Duration	1 hour	1 hour	1 hour	1 hour
Power consumed	14	45	869	1001
Costing(RM)	0.00	0.01	0.28	0.32
Appliances	16 watt Led light	Stand fan 60 watt	Loud Speaker 200watt	Vacuum cleaner 1300watt
Duration	2 hour	2 hour	2 hours	2 hours
Power consumed	14	45	120	990
Costing(RM)	0.01	0.03	0.08	0.63

These home appliances are tested according to their usage time. The hairdryer is not used more than 1 hour because it gets hot when it's used for long duration. To avoid any accident, the smart power adapter is tested with loudspeaker and a vacuum cleaner for 2 hours. This costing is calculated based on the monthly basis.

This is because the amount of cost that it take for one hour is very small. Thus calculating the cost based on hours and power consumption then scale it on total for the month. This costing results is tested with the reference of the tariff table. The tariff table is shown in Fig 11.

TARIFF CATEGORY	UNIT	RATES
1. Tariff A - Domestic Tariff		
For the first 200 kWh (1 - 200 kWh) per month	sen/kWh	21.8
For the next 100 kWh (201 - 300 kWh) per month	sen/kWh	33.4
For the next 100 kWh (301 - 400 kWh) per month	sen/kWh	40.0
For the first 100kWh (401 - 500 kWh) per month	sen/kWh	40.2
For the next 100 kWh (501 - 600 kWh) per month	sen/kWh	41.6
For the next 100 kWh (601 - 700 kWh) per month	sen/kWh	42.6
For the next 100 kWh (701 - 800 kWh) per month	sen/kWh	43.7
For the next 100 kWh (801 - 900 kWh) per month	sen/kWh	45.3
For the next kWh (901 kWh onwards) per month	sen/kWh	45.4

Fig. 11. Tariff Table

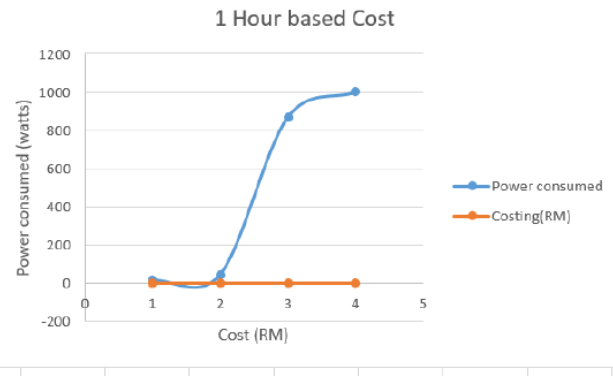
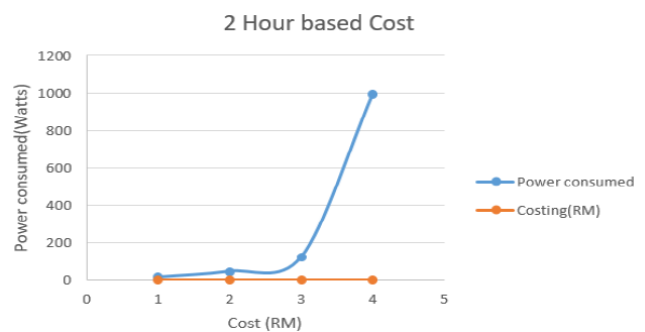

Fig. 12. One hour Costing Graph



D. Efficiency Test 4

This testing is to monitor the amount of time taken to recharge the battery from 0 to 100%. Then the time taken to use up all the battery power by charging mobile phones. The rechargeable battery is connected to smartphone for monitoring the time taken to finish the power balance. Then from the BLYNK application the smart adapter will be controlled to recharge the battery along the time is being recorded. The table below shows the time need to use up all the battery power and time taken to recharge the battery to 100%.

TABLE IV. BATTERY EFFICIENCY

Duration (minutes)	Recharge (%)	Consume (%)
15	5	93
30	12	86
60	21	76
120	28	63
140	36	47
160	45	34
200	56	24
230	71	8
300	98	0
315	100	0

The battery percentage for the consumption and also to recharge is tested for the consumption duration. The output of this batteries are 5V 2.1A. This battery is tested with an android mobile phone that has a battery capacity of 1350mAh. From the results, the battery percentage reduces in small range for to the time proportional. The phone battery is kept at 1 % to test the charging time for the mobile phone to be full. The

mobile phone is fully charged and the battery percentage in the adapter left at 63 % after 1 hour 15 minutes of charging.

Then the process to completely use the power in the battery is continued by charging other mobile phone. The time taken for the rechargeable battery to fully recharge took more time than expected. The battery fully consumed at 230 minutes which is 3.8 hours. Where else the charging time take 315 minutes which is 5 hours. This is because there will be some minor energy loss during the recharging process.

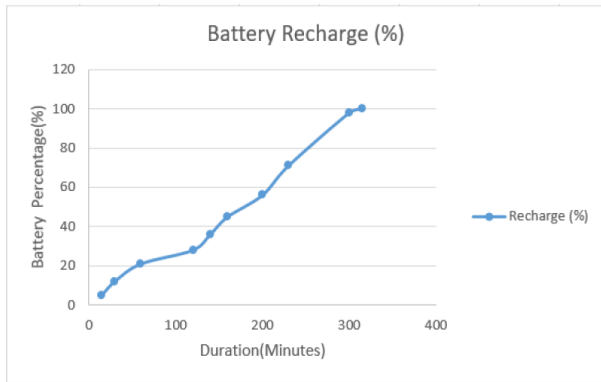

Fig. 13. Battery Recharge

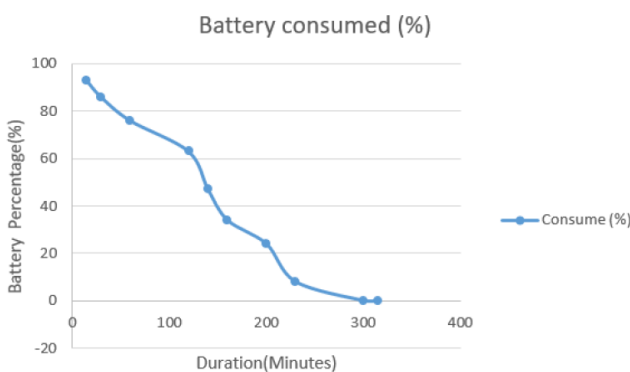

Fig. 14. Battery consumed data Graph

VI. Conclusion

In a nutshell, the aim of this research is to develop a smart IOT based Power Adapter. This smart IOT based power adapter contains a 3Pin plug input for power connection. This adapter comes along with two outputs which are AC and DC output current. At the front face of the smart Power Adapter there will be a small LED screen to display back up DC power voltage. This Smart Power Adapter able to recognize the amount of power consumed and able to provide wireless connection between the adapter and the application as a medium to control the adapter. Besides that, the power adapter will also contain rechargeable battery backup power to produce DC current of 5V 2.1A. The limitation of this smart power adapter is, it is not able to store the data of power consumed and costing. The data will be carried for one month and vanish after that. The database for the power adapter is not created. The total cost for the power consumed can only be

last seen every month. This is because the chart and database is not created separately.

References

- [1] S. M. SHINDE, J.D NANAWARE, "IOT (Internet of things) Based Wireless Smart Socket," *International Journal of Engineering Trends and Technology (IJETT)*, vol. 55, pp. 56–60, 2018.
- [2] J. Feng, W. Fei, D. Jian, and Z. Yan, "Design of Socket Based on Intelligent Control and Energy Management," *Int. J. Adv. Comput. Sci. Appl.*, vol. 6, no. 10, pp. 105–110, 2015.
- [3] A. Kurde and V. Kulkarni, "IOT Based Smart Power Metering," *Int. J. Sci. Res. Publ.*, vol. 6, no. 9, pp. 411–415, 2016.
- [4] K. A. Fakeeh ., "An IOT based smart power mangement system for technical university", *International Journal of Computer Applications Volume 149 – No.1*, pp. 0975 – 8887, September 2016.
- [5] I. M. Nayyef, A. A. H. Husein, " Design and Implementation of IOT Based Smart Power Monitoring and Management System Using WSNS," *International Journal of Embedded Systems and Applications (IJESA)*, Vol 8, No.4, December 2018.
- [6] P. Gupta, J. Chhabra, "IoT-based smart home design using power and security mangement," *International Conf. on Innovation and Challenges in Cyber security*, pp. 6-10, August 2016.
- [7] S.-H. Lee and C.-S. Yang, "An intelligent power monitoring and analysis system for distributed smart plugs sensor networks," *Int. J. Distrib. Sensor Netw.*, vol. 13, no. 7, pp. 1–13, 2017.
- [8] O. M. Machidon, C. Stanca, P. Ogrutan, C. Gerigan, and L. Aciu, "Powersystem protection device with IoT-based support for integration in smart environments," *PLoS ONE*, vol. 13, no. 12, pp. 1–22, Dec. 2018.
- [9] M. Ali and M. K. Paracha, "An IoT Based Approach for Monitoring Solar Power Consumption with Adafruit Cloud," *Int. J. Eng. Appl. Sci. Technol.*, vol. 4, no. 9, pp. 335–341, 2020.
- [10] A. R. Al-Ali, I. A. Zualkernan, M. Rashid, R. Gupta, and M. Alikarar, "A smart home energy management system using IoT and big data analytics approach," *IEEE Trans. Consum. Electron.*, vol. 63, no. 4, pp. 426–434, Nov. 2017.
- [11] D. Dziak, B. Jachimczyk, and W. J. Kulesza, "IoT-based information system for healthcare application: Design methodology approach," *Appl. Sci.*, vol. 7, no. 6, pp. 596, Jun. 2017.
- [12] S. K. Lee, M. Bae, and H. Kim, "Future of IoT networks: A survey," *Appl. Sci.*, vol. 7, no. 10, pp. 1072, 2017.
- [13] P. V. R. RAJU, G. N. RAJU, G. V. P. S. MANIKANTAH, ABDUL VAHED, A. LBHAVYAW, G. REDDY. IOT Based Power Monitoring System and Control. *International Journal of Emerging Technology and Innovative Research*, vol. 4(11), pp.118-122, 2017.
- [14] I. Abdulazeez, A. Omoregie, A.B. Oshomah, "Design and Construction of an Automatic Emergency Lighting system with battery over-charge Protection Circuit," *Greener Journal of Science Engineering and Technological Research*, vol. 5 (1), pp.1-15, 2015.
- [15] N. RAJATHI &SUGANTHI, "Automatic Electricity Bill Generating System," *International Journal of Recent Technology and Engineering*, vol. 7(11), pp. 8-11, 2018.